



INFLIGHT FITNESS

CT-MSEC

Seated Leg Extension/Leg Curl



STANDARD FEATURES

- ✓ Unique cable system provides immediate resistance.
- ✓ Seat pads are ergonomically angled to position you for a complete muscle exercise as well as comfort.
- ✓ Large 2" x 4" flat oval tube frame is rugged and stylish.

OPTIONAL FEATURES

- ✓ Steel shrouds powder coated and clear coated for a mar resistant and lustrous finish.
- ✓ Standard 150lb. weight stack may be upgraded in 50lb. increments to 300lbs.



Easy to use ratchet adjusts back pad to accommodate varying leg lengths.



Exercise roller pad self-adjusts to your ankles.

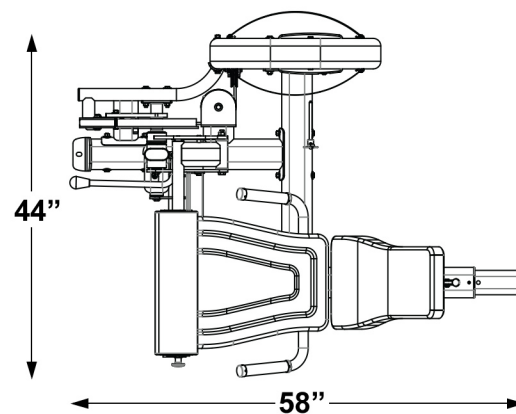

Visit www.inflightfitness.com to see our entire line of exercise equipment.

Lifetime limited warranty on frame, welds, and weights, 3 years on bearings, guide rods, cams, and pulleys, 1 year on cables.

See warranty for details.